

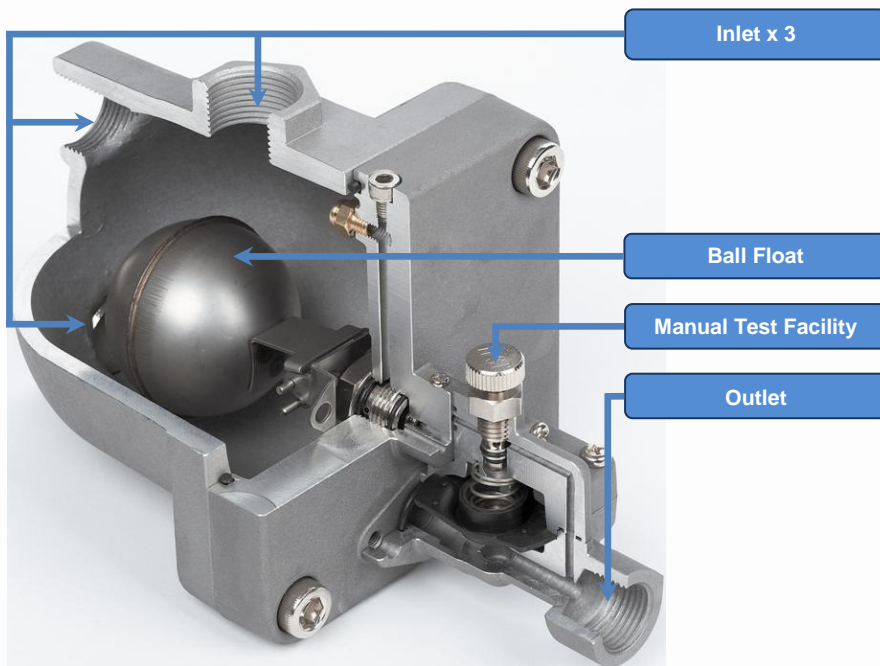

Mechanical No Loss Drain 340 Series

The Mechanical No Loss Drain removes harmful condensate from receiver tanks, aftercoolers, dryers, filters and drip legs.



- ✓ **Reliable**
- ✓ **Fully Automatic**
- ✓ **Compact**
- ✓ **Rugged**
- ✓ **No Electricity**
- ✓ **No Air Loss**
- ✓ **Manual Test Function**
- ✓ **Easy Service**
- ✓ **Easy Installation**
- ✓ **Available In Three Pressure Ranges**
- ✓ **Models for both Oil-free and Oil Injected Applications**

Operation

- ◆ Initially, diaphragm is kept closed by system pressure.
- ◆ Condensate collects inside the unit through the inlet, gradually causing the ball float to rise.
- ◆ Upon reaching a predetermined height, the ball float opens the pilot valve. This relieves the pressure chamber above the diaphragm.
- ◆ As a result, the pressure of the condensate lifts the diaphragm, allowing the collected condensate to be discharged.
- ◆ As the condensate is discharged, the float sinks, closing the pilot valve. Compressed air then flows over the diaphragm, sealing it again.

Benefits / Features

- ◆ Improves air system performance
- ◆ Eliminates frequent downtime maintenance
- ◆ Prevents corrosion and scaling
- ◆ Increases the air-carrying capacity of the pipelines
- ◆ Extends equipment life
- ◆ Aluminium body with stainless steel internals
- ◆ Maximum working pressure up to 250 PSI
- ◆ Manual test function
- ◆ 7mm outlet for quick discharge of condensate
- ◆ Optional extras include a heating unit to prevent freezing and bursting of pipelines in winter and pre-filter ball valves to prolong lifespan of the unit



Mechanical No Loss Drain

340 Series

Technical Data

Air Compressor Performance (max)	130m ³ /min			
Normal Flow Volume	6 l/hr			
Short term peak load (from 7.0Bar)	30 l/hr			
Temperature (min/max)	+0°C to +60°C			
Condensate Inlet	3/4" x 3			
Condensate Discharge	1/2" x 1			
Weight	2.3kg			
Model	A	B	C	D
020 Model	3/4"	1/2"	129 mm	210 mm

Dimensions

340 Series

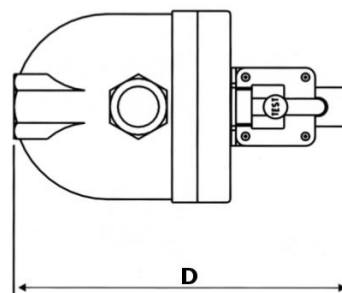
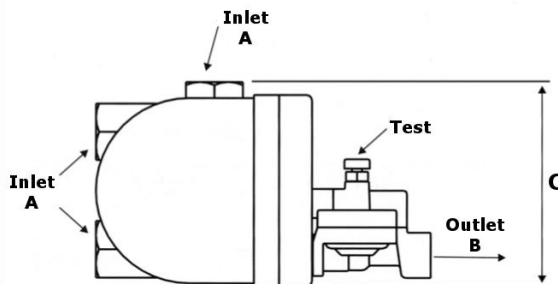
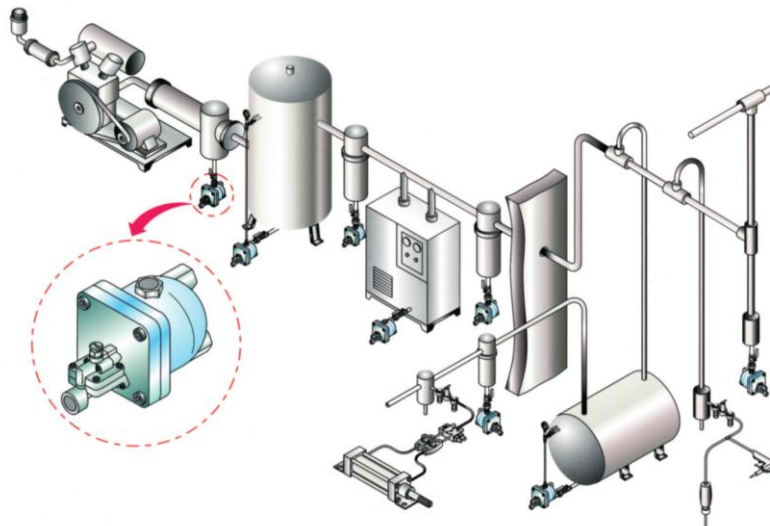

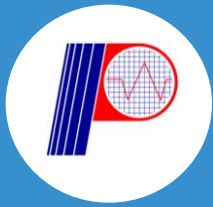

Mechanical No Loss Drain 340 Series

Order Reference: 020 Model			
Pt. No:	Thread Type	Application	Operating Pressure (min/max Bar)
340-01-020L	NPT	Oil Injected Compressor	0.8 - 3.0
340-01-020N	NPT	Oil Injected Compressor	3.0 - 9.9
340-01-020H	NPT	Oil Injected Compressor	10 - 16
340-01-020LC	NPT	Oil Free Compressor	0.8 - 3.0
340-01-020NC	NPT	Oil Free Compressor	3.0 - 9.9
340-01-020HC	NPT	Oil Free Compressor	10 - 16
340-11-020L	BSP	Oil Injected Compressor	0.8 - 3.0
340-11-020N	BSP	Oil Injected Compressor	3.0 - 9.9
340-11-020H	BSP	Oil Injected Compressor	10 - 16
340-11-020LC	BSP	Oil Free Compressor	0.8 - 3.0
340-11-020NC	BSP	Oil Free Compressor	3.0 - 9.9
340-11-020HC	BSP	Oil Free Compressor	10 - 16

